

MODEL QUESTION PAPER (2020-21)
PHYSICS (THEORY)

MM: 70 Marks

Time : 3 hours

General Instructions:

- (1) All questions are compulsory. There are 33 questions in all.
- (2) This question paper has five sections: Section A, Section B, Section C, Section D and Section E.
- (3) Section A contains ten very short answer questions and four assertion reasoning MCQs of 1 mark each, Section B has two case based questions of 4 marks each, Section C contains nine short answer questions of 2 marks each, Section D contains five short answer questions of 3 marks each and Section E contains three long answer questions of 5 marks each.
- (4) There is no overall choice. However internal choice is provided. You have to attempt only one of the choices in such questions.

SECTION–A

All questions are compulsory. In case of internal choices, attempt any one of them.

1. Why electrostatics field lines do not form closed loop? [1]
2. Which part of the electromagnetic spectrum is used in RADAR? Give it's frequency range. [1]

OR

How are electromagnetic waves produced by accelerating charges?

3. Write the relation for the force acting on a charged particle q moving with velocity \vec{v} in the presence of a magnetic field \vec{B} . [1]
4. Define 'quality factor' of resonance in series LCR circuit. What is it's SI unit? [1]
5. Write the underlying principle of a moving coil galvanometer. [1]
6. What is the ratio of radii of the orbits corresponding to first excited state and ground state in a hydrogen atom? [1]
7. How is the radius of a nucleus related to its mass number? [1]

OR

Select the pairs of isobars from the following nuclei ? ${}_{11}\text{Na}^{22}$, ${}_{11}\text{Na}^{23}$, ${}_{10}\text{Ne}^{23}$.

8. Name one impurity each, which when added, to pure Si, produces [1]
(i) n-type, and (ii) p-type semiconductor.

OR

State the reason, why GaAs is most commonly used in making of a solar cell.

9. Draw a schematic diagram of a reflecting telescope. [1]
10. Define the term 'Coherent Source' which are required to produce interference pattern in Young's double slit experiment. [1]



For question numbers 11, 12, 13 and 14, two statements are given-one labelled Assertion (A) and the other labelled Reason (R). Select the correct answer to these questions from the codes (a), (b), (c) and (d) as given below.

- (a) Both A and R are true and R is the correct explanation of A
- (b) Both A and R are true but R is NOT the correct explanation of A
- (c) A is true but R is false
- (d) A is false and R is also false

11. **Assertion(A) :** Whenever magnetic flux linked with the coil changes with respect to time, then an emf is induced in it. [1]
Reason(R): According to Lenz law, the direction of induced emf in any coil is such a way that it always opposes the cause by which it is produced.
12. **Assertion :** Coulomb's law in electrostatics holds good for two point charges at rest. [1]
Reason : When the charges are in motion, the force is electromagnetic in nature.
13. **Assertion :** For the scattering of α -particle at a large angles, only the nucleus of the atom is responsible. [1]
Reason : Nucleus is very heavy in comparison to electrons.
14. **Assertion(A) :** Conductivity of semiconductor increases on doping. [1]
Reason(R): Doping raises the temperature of semiconductor.

SECTION – B

Questions 15 and 16 are Case Study based questions and are compulsory. Attempt any 4 sub parts from each question. Each question carries 1 mark.

15. **Meter Bridge :**

The meter bridge consists of a wire of length 1m and of uniform cross sectional area stretched taut and clamped between two thick metallic strips bent at right angles, as shown. The metallic strip has two gaps across which resistors can be connected. The end points where the wire is clamped are connected to a cell through a key. One end of a galvanometer is connected to the metallic strip midway between the two gaps. The other end of the galvanometer is connected to a 'jockey'. The jockey is essentially a metallic rod whose one end has a knife-edge which can slide over the wire to make electrical connection. If the jockey is moved along wire, then there will be one position where galvanometer will show no current (i.e. balanced condition). [4]

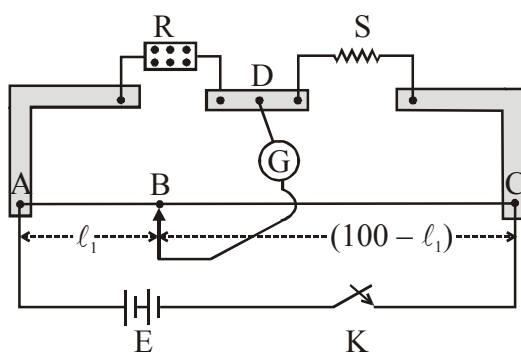

1. Resistance of the two gaps of a meter bridge are 10 ohm and 30 ohm respectively. If the resistances are inter changed, the balance point shift by :
 (a) 33.3 cm (b) 66.67 cm (c) 25 cm (d) 50 cm
2. A galvanometer acting as a voltmeter will have :
 (a) A low resistance in series with its coil (b) A low resistance in parallel with its coil
 (c) A high resistance in series with its coil (d) A high resistance in parallel with its coil

3. An unknown resistance is placed on the left gap and known resistance of 60Ω in right gap of meter bridge. The null point is obtained at 40 cm from left end of the bridge. Select the value of unknown resistance :
 (a) 60Ω (b) 30Ω (c) 40Ω (d) 20Ω
4. The principle of meter bridge is based on the balanced condition of :-
 (a) Potentiometer (b) Wheatstone bridge
 (c) Transformer (d) Galvanometer
5. In meter bridge experiment balanced point adjusted at the middle of the bridge because of :
 (a) The percentage error in determination of unknown resistance can be minimised
 (b) Range can be increased
 (c) Sensitivity can be minimised
 (d) Range can be decreased
16. **Sparking Brilliance of Diamond:** [4]

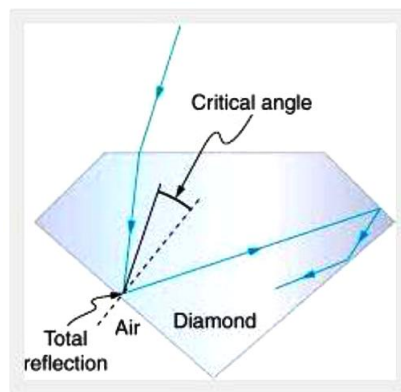

The total internal reflection of the light is used in polishing diamonds to create a sparking brilliance. By polishing the diamond with specific cuts, it is adjusted the most of the light rays approaching the surface are incident with an angle of incidence more than critical angle. Hence, they suffer multiple reflections and ultimately come out of diamond from the top. This gives the diamond a sparking brilliance.

1. Light cannot easily escape a diamond without multiple internal reflections. This is because:
 (a) Its critical angle with reference to air is too large
 (b) Its critical angle with reference to air is too small
 (c) The diamond is transparent
 (d) Rays always enter at angle greater than critical angle
2. The critical angle for a diamond is 24.4° . Then its refractive index is-
 (a) 2.42 (b) 0.413 (c) 1 (d) 1.413
3. The basic reason for the extraordinary sparkle of suitably cut diamond is that
 (a) It has low refractive index (b) It has high transparency
 (c) It has high refractive index (d) It is very hard

4. A diamond is immersed in a liquid with a refractive index greater than water. Then the critical angle for total internal reflection will
- (a) will depend on the nature of the liquid (b) decrease
 (c) remains the same (d) increase
5. The following diagram shows same diamond cut in two different shapes.

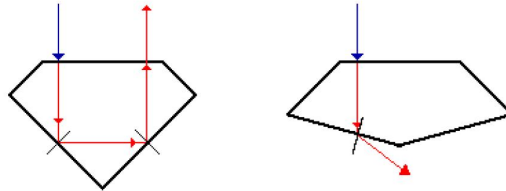

The brilliance of diamond in the second diamond will be:

- (a) less than the first (b) greater than first
 (c) same as first (d) will depend on the intensity of light

SECTION-C

All questions are compulsory. In case of internal choices, attempt anyone.

17. Find the condition under which the charged particles moving with different speeds in the presence of electric and magnetic field vectors can be used to select charged particles of a particular speed. [2]
18. Give any two differences between fringes formed in single slit diffraction and Young's double slit experiment. [2]

OR

State Huygens's principle for constructing wave fronts.

19. Explain the terms: [2]
- (i) quantization of charge
 (ii) conservation of charge

OR

Electric field intensity within a conductor is always zero. Why? [2]

20. Current in a circuit falls from 5.0 A to 0.0 A in 0.1 s. If an average emf of 200 V induced, give an estimate of the self-inductance of the circuit. [2]
21. A rectangular loop PQMN with movable arm PQ of length 10 cm and resistance 2Ω is placed in a uniform magnetic field of 0.1 T acting perpendicular to the plane of the loop as is shown in the figure. The resistances of the arms MN, NP and MQ are negligible. Calculate the (i) emf induced in the arm PQ and (ii) current induced in the loop when arm PQ is moved with velocity 20 m/s. [2]

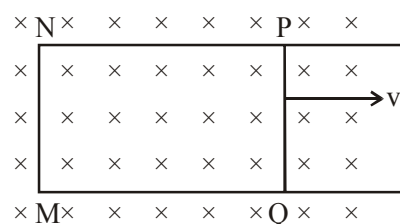

22. A double convex lens is made of a glass of refractive index 1.55, with both faces of the same radius of curvature. Find the radius of curvature required, if the focal length is 20 cm. [2]
23. Explain with the help of a diagram the formation of depletion region and barrier potential in a p-n junction. [2]
24. Name the elements of the earth's magnetic field. Define any two of them. [2]

OR

In the magnetic meridian of a certain place, the horizontal component of the earth's magnetic field is 0.26G and the dip angle is 60° . What is the magnetic field of the earth at this location?

25. State two properties of electromagnetic waves. How can we show that EM waves carry momentum? [2]

SECTION -D

All questions are compulsory. In case of internal choices, attempt any one.

26. (a) Derive, with the help of a diagram, the expression for the magnetic field inside a very long solenoid having n turns per unit length carrying a current I . [3]
 (b) How is a toroid different from a solenoid?
27. In the following potentiometer circuit AB is a uniform wire of length 1 m and resistance 10Ω . Calculate the potential gradient along the wire and balance length $AO (= \ell)$. [3]

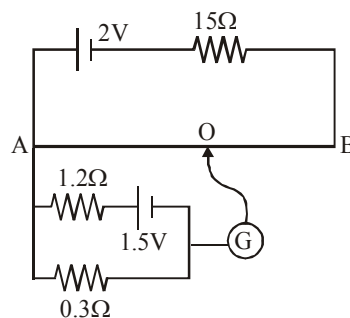

OR

Two identical cells of emf 1.5 V each joined in parallel to supply energy to an external circuit consisting of two resistances of 7Ω each joined in parallel. A very high resistance voltmeter reads the terminal voltage of cells to be 1.4 V. Calculate the internal resistance of each cell.

28. (a) Show that the de-Broglie wavelength of the electrons of energy E is given by the relation

$$\lambda = \frac{h}{\sqrt{2mE}} \quad [3]$$

- (b) What is the de-Broglie wavelength of an atom at absolute temperature T ?

OR

- (a) Write Einstein photoelectric equation and use it to explain:

- (i) Independence of maximum energy of emitted photoelectrons from intensity of incident light,
 (ii) Existence of threshold frequency for emission of photoelectrons.

29. The fission properties of ${}_{94}\text{Pu}^{239}$ are very similar to those of ${}_{92}\text{U}^{235}$. The average energy released per fission is 180 MeV. How much energy, in MeV, is released if all the atoms in 1 kg of pure ${}_{94}\text{Pu}^{239}$ undergo fission? [3]
30. When is H_{α} line in the emission spectrum of hydrogen atom obtained? Calculate the frequency of the photon emitted during this transition. [3]

SECTION – E

All questions are compulsory. In case of internal choices, attempt any one.

31. (i) Use Gauss' law to find the electric field due to a uniformly charged infinite plane sheet. What is the direction of field for positive and negative charge densities? [5]
- (ii) Find the ratio of the potential differences that must be applied across the series and parallel combination of two capacitors C_1 and C_2 with their capacitances in the ratio 1 : 2 so that the energy stored in the two cases becomes the same.

OR

- (a) Derive an expression for the electric field E due to a dipole of length '2a' at a point distant r from the centre of the dipole on the axial line.
- (b) Draw a graph of E versus r for $r \gg a$.
- (c) If this dipole were kept in a uniform external electric field E_0 , diagrammatically represent the position of the dipole in stable and unstable equilibrium and write the expressions for the torque acting on the dipole in both the cases.
32. A $2 \mu\text{F}$ capacitor, 100Ω resistor and 8 H inductor are connected in series with an AC source.
- (i) What should be the frequency of the source such that current drawn in the circuit is maximum, What is this frequency called? [5]
- (ii) If the peak value of e.m.f. of the source is 200 V , find the maximum current.
- (iii) Draw a graph showing variation of amplitude of circuit current with changing frequency of applied voltage in a series LCR circuit for two different values of resistance R_1 and R_2 ($R_1 > R_2$).

OR

In a series LCR circuit connected to an a.c. source of voltage $V = V_m \sin \omega t$, use phasor diagram to derive an expression for the current in the circuit. Hence obtain the expression for the power dissipated in the circuit. Show that power dissipated at resonance is maximum.

33. What do you mean by diffraction of light? Explain diffraction at a single slit and deduce expression for width of its central maxima. [5]

OR

Define wavefront. Use Huygens' principle to verify the laws of refraction.



MODEL PAPER- (SOLUTIONS) 2020-21

(PHYSICS)

SECTION – A

1. The field lines start (or diverge) from the positive charge and terminate (or converge) on negative charge. If electric field lines form closed loops, then these lines must originate and terminate on the same charge which is not possible. So, electric field lines can't form closed loop.
[Also accept, if students write, electric field is conservative nature.] [1]

2. Microwave is used in RADAR with frequency range b/w 3×10^{10} Hz – 10^{12} Hz [1]

OR

An accelerated charge produces an oscillating electric field in space which produces an oscillating magnetic field, which is again a source of oscillating electric field and so on. As a result electro magnetic wave is produced.

3. $\vec{F} = q(\vec{v} \times \vec{B})$ [1]
4. The quality factor (Q) factor of series LCR resonant circuit is defined as the ratio of the voltage developed across the inductor or capacitor at resonance to the applied voltage, which is the voltage across R. [1]

$$Q = \frac{IX_L}{IR} = \frac{\omega_0 L}{R}$$

It is dimensionless hence, it has no units.

OR

Quality factor represents sharpness of resonance and is given as $Q = \frac{\omega_r}{\omega_2 - \omega_1}$

it is unitless.

5. Moving coil galvanometer works on the principle that when a current carrying coil placed in a magnetic field, it experiences a torque so, it get deflected and by measuring deflection we can measure current. [1]
6. $r_n \propto n^2 \Rightarrow r_2 / r_1 = 4/1$ [1]
7. The radius of a nucleus of mass number A is related as if $R = R_0 A^{1/3}$, where R_0 is a constant. [1]

OR

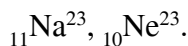

8. (i) As (Pentavalent impurity) (ii) Al (Trivalent impurity) [1]

OR

GaAs are preferred material because –

- (a) Band gap (~ 1.0 to 1.8 eV) (b) High optical absorption (~ 10^4 cm^{-1})
(c) Electrical conductivity (d) Availability of raw material
(e) Low cost.

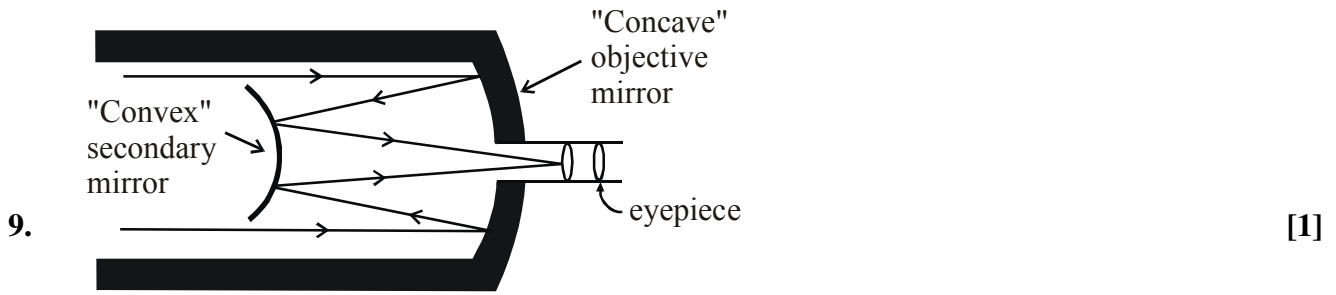

(Reflecting telescope)

10. Two sources are perfectly coherent if their frequency is same and their phase difference is constant. [1]
11. (b) [1]
12. (a) [1]
13. (a) [1]
14. (c) [1]

SECTION – B

15. (i) d, (ii) c, (iii) c, (iv) b, (v) a [4 × 1 = 4]
16. (i) b, (ii) a, (iii) c, (iv) d, (v) d [4 × 1 = 4]

SECTION–C

17. Consider a charge 'q' moving with velocity \vec{v} in the presence of both electric field (\vec{E}) & magnetic field (\vec{B}) experiences a force given as- [2]

$$\vec{F} = q(\vec{E} + \vec{v} \times \vec{B}) = \vec{F}_E + \vec{F}_B$$

Assume, \vec{E} & \vec{B} are \perp to each other & also \perp to the velocity of the particle.

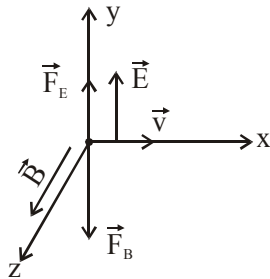

Directions of electric force (\vec{F}_E) & magnetic force (\vec{F}_B) are just opposite.

$$\therefore \vec{F} = q(\vec{E} - v\vec{B})\hat{j}$$

if magnitudes of electric and magnetic force are equal then, net force on the particle is zero & it will move undeflected in the fields.

$$qE = qvB \text{ or } \boxed{v = E/B}$$

The above condition is used to select charged particles of a particular velocity.



18. (1) In Young's experiment, all the bright fringes formed are of same intensity, whereas in single slit diffraction experiment, the bright fringes are of varying intensity. [2]
- (2) In Young's experiment, fringes of minimum intensity are perfectly dark, whereas in single slit diffraction experiment, fringes of minimum intensity are not perfectly dark.

OR

According to Huygens's principle

- (1) Each source of light spreads waves in all directions.
- (2) Each point on the wavefront give rise to new disturbance which produces secondary wavelets which travels with the speed of light.
- (3) Only forward envelope which encloses the tangent gives the new position of wave front.
- (4) Rays are always perpendicular is the wavefront.
19. (i) **Charge is quantized** : Charge on any body always exists in integral multiples of a fundamental unit of electric charge. This unit is equal to the magnitude of charge on electron ($1e = 1.6 \times 10^{-19}$ coulomb). So charge on anybody is $Q = \pm ne$, where n is an integer and e is the charge of the electron. Millikan's oil drop experiment proved the quantization of charge or atomicity of charge
- (ii) **Charge is conserved** : In an isolated system, total charge (sum of positive and negative) remains constant whatever change takes place in that system. [2]

20. Change in current $dI = 0 - (5) = -5A$ [2]
 Change in time $dt = 0.1 s$
 average emf $\varepsilon = 200 V$

$$\Rightarrow \varepsilon = -L \frac{dI}{dt}$$

$$200 = L \left(\frac{5}{0.1} \right) \Rightarrow L = \frac{20}{5} = 4H$$

21. (i) Induced emf in arm PQ [2]
 $e = -B/v$
 $e = -0.1 \times 10 \times 10^{-2} \times 20$
 $e = -0.2 V$

(ii) Current induced in loop

$$I = \frac{|e|}{R} = \frac{0.2}{2} = 0.1A$$



22. From $\frac{1}{f} = (\mu_{21} - 1) \left[\frac{1}{R_1} - \frac{1}{R_2} \right]$ [2]

$$\frac{1}{f} = (1.55 - 1) \left[\frac{1}{R} - \left(-\frac{1}{R} \right) \right] \quad \because R_1 = R_2 = R$$

$$\frac{1}{f} = (.55) \left[\frac{2}{R} \right] = \frac{1.1}{R}$$

$$\frac{1}{20} = \frac{1.1}{R} \Rightarrow R = 1.1 \times 20 = 22 \text{ cm}$$

23. It is clear that, N-type semiconductor has an excess of free electrons and P-type has an excess of holes therefore when both are placed together to form a junction, electrons move towards the P-side and holes move towards N-side due to concentration gradient. Departure of an electron from the N-side to the P-side leaves a positive donor ion on N-side and likewise hole leaves a negative acceptor ion on the P-side resulting in the formation of depletion layer having width $\approx 10^{-7} \text{ m}$. [2]

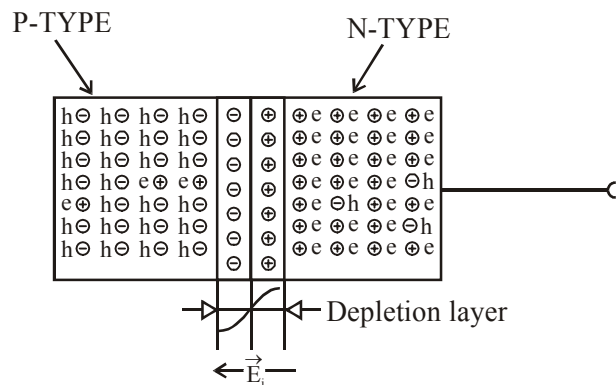

Depletion layer : It is the layer near the junction in which electrons are absent on n side and holes are absent on p side.

Potential barrier : Due to the accumulation of immobile ions near the junction an electric potential difference (V_b) develops b/w n side & p side which acts as a barrier for further diffusion of electrons and holes.

$$V_b = E_i \times d \quad (\text{volt})$$

24. Earth's magnetic components :- [2]

- (1) Declination Angle (2) Dip Angle or Angle of inclination
(3) Horizontal Component of earth's magnetic field

- (1) **Angle of declination (ϕ) :-** It is the acute angle between magnetic meridian and geographical meridian at a given place.

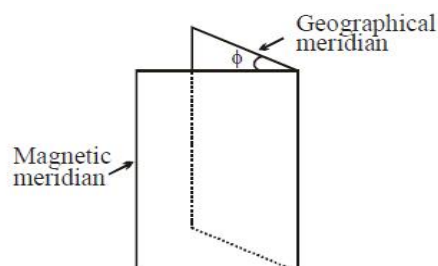

(2) **Dip Angle(θ)** :- It is direction horizontal resultant magnetic field of earth in magnetic meridian. Dip angle at magnetic pole of earth is 90° and at magnetic equator it is 0° .

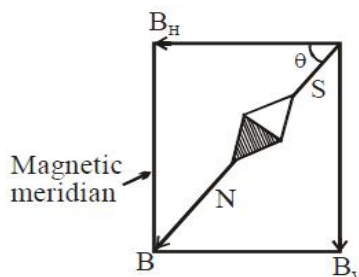

$B \Rightarrow$ resultant magnetic field of earth's magnetism

$B_H \Rightarrow$ Horizontal component

$B_v \Rightarrow$ Vertical component

OR

Given $B_H = 0.26 \text{ G}$

$$\cos 60^\circ = \frac{B_H}{B}$$

$$B = \frac{B_H}{\cos 60^\circ} = \frac{0.26}{(1/2)} = 0.52 \text{ G}$$

25. (i) The electromagnetic waves are produced by accelerated charge particles and do not require any material medium for their propagation. [2]
- (ii) The oscillation of the fields E and B are in same phase and their direction are perpendicular to each other.

An electromagnetic wave transport linear momentum as it travels through space.

If an electromagnetic wave transfer a total energy U to a surface in time t , then total linear momentum delivered to the surface is $P = U/c$

If the wave is totally reflected, then the momentum delivered will be $2U/c$ because the momentum of the wave will change from P to $-P$

SECTION -D

26. (a) [3]

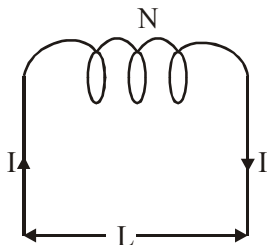

Here, we consider a current-carrying solenoid having total no of turns N .

$$\therefore \text{no of turns per unit length, } n = \frac{N}{L}$$



On applying ACL for the cross-sectional view of this solenoid.

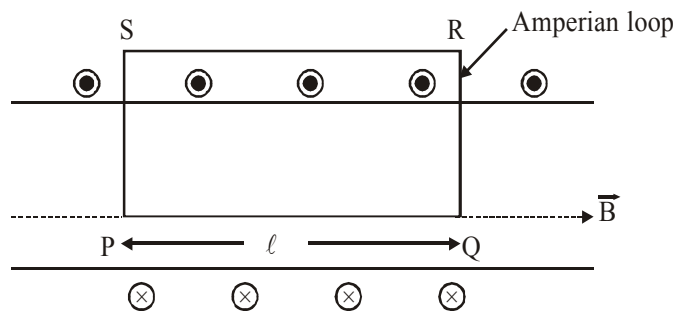

$$\oint \vec{B} \cdot d\vec{\ell} = \int_P^Q \vec{B} \cdot d\vec{\ell} + \int_Q^R \vec{B} \cdot d\vec{\ell} + \int_R^S \vec{B} \cdot d\vec{\ell} + \int_S^P \vec{B} \cdot d\vec{\ell}$$

$$\int_P^Q B dl \cos 0^\circ + \int_Q^R B dl \cos 90^\circ + \int_R^S (0) + \int_S^P B dl \cos 90^\circ = \int_P^Q B dl$$

From ACL,

$$B \oint d\ell = \mu_0 (\Sigma I)$$

$$\therefore B l = \mu_0 (n l I)$$

$$\boxed{B = \mu_0 n I}$$

(b) A solenoid has N-S poles whereas toroid doesn't have separate poles.

27. Current in the following circuit :

[3]

$$I = \frac{E}{R + R_w} \quad R_w = \text{Resistance of potentiometer wire AB}$$

$$I = \frac{2}{15 + 10} = 0.08 \text{ A}$$

So potential difference across wire

$$AB = \text{current} \times \text{Resistance of wire} = 0.08 \times 10 = 0.8 \text{ V}$$

$$\text{So potential gradient along AB} = \frac{\text{Potential difference along AB}}{\text{length of AB}} = \frac{0.8}{1} = 0.8 \text{ V/m}$$

Terminal potential of test cell (secondary ckt)

$$V = E - I' \times r \quad \left[I' = \frac{1.5}{1.2 + 0.3} = 1 \text{ A} \right]$$

$$V = 1.5 - 1 \times 1.2 = 0.3 \text{ V}$$

Since drop on balancing length of potentiometer wire balance the terminal potential difference of the test cell.

$$\text{So length of AO} = V_{AO} / \text{Potential gradient along} = \frac{0.3}{0.8} = \frac{3}{8} \text{ m}$$

OR

A high resistance voltmeter means that no current flow through the voltmeter (practically very less current). When two batteries are connected in parallel, then

$$E_{eq} = \frac{E_1 r_2 + E_2 r_1}{r_1 + r_2}$$

Here $r_1 = r_2 = r$

$$E_1 = E_2 = 1.5V \quad (\text{given})$$

$$E_{eq} = \frac{1.5 \times r + 1.5 \times r}{2r}$$

$$E_{eq} = 1.5V$$

Now $R_1 = 7\Omega$
 $R_2 = 7\Omega$ } given

$$\text{So } \frac{1}{R_{eq}} = \left(\frac{1}{7} + \frac{1}{7} \right) \Omega$$

$$R_{eq} = \frac{7}{2} = 3.5\Omega$$

$$\therefore I = \frac{\text{terminal voltage}}{\text{equivalent resistance}}$$

$V = \text{terminal voltage} = 1.4$ (given) = voltmeter reading

$$\text{So } I = \frac{1.4}{3.5} = 0.4A$$

$$\begin{aligned} \text{Now } V &= E_{eq} - I \times r_{eq} \\ 1.4 &= 1.5 - 0.4 \times r_{eq} \\ 0.4 \times r_{eq} &= 0.1 \\ r_{eq} &= 0.25\Omega \end{aligned}$$

$$\text{As } r_{eq} = r/2 \quad \left(\because \frac{1}{r_{eq}} = \frac{1}{r} + \frac{1}{r} \right)$$

So r of each cell = 0.5Ω

$$28. \quad (a) \quad E = \frac{1}{2}mv^2 \quad \Rightarrow \quad v = \sqrt{\frac{2E}{m}} \quad [3]$$

$$\text{But } v = \frac{h}{m\lambda} \quad \therefore \quad \frac{h}{m\lambda} = \sqrt{\frac{2E}{m}}$$

$$\Rightarrow \quad \lambda = \frac{h}{\sqrt{2mE}}$$

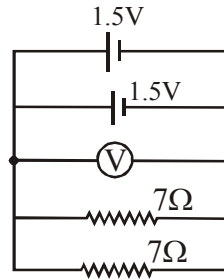

$$(b) \lambda = \frac{h}{\sqrt{2mE_k}} = \frac{h}{\sqrt{2m\left(\frac{3}{2}kT\right)}}$$

$$\Rightarrow \lambda = \frac{h}{\sqrt{3mkT}}$$

$$\lambda \propto \frac{1}{\sqrt{T}}$$

OR

$$K.E_{\max} = \frac{1}{2}mv_{\max}^2 = h\nu - \phi_0$$

- (i) Number of photoelectrons emitted per second from a metal surface depends on the number of photons incident on that surface in one second. If intensity of the incident radiations is increased therefore the number of photoelectrons emitted increases.

Therefore KE_{\max} is independent of the incident lights intensity.

- (ii) If $\nu < \nu_0$, KE_{\max} is negative which is impossible.

29. The number of atoms in 1kg of ${}_{94}\text{Pu}^{239}$ [3]

$$= \frac{6.023 \times 10^{23} \times 1000}{239}$$

Energy released per fission = 180 MeV

Energy released by 1kg of ${}_{94}\text{Pu}^{239}$

$$= \frac{6.023 \times 10^{23} \times 1000}{239} \times 180 \text{ MeV}$$

$$= 4.53 \times 10^{26} \text{ MeV}$$

30. H_α is a specific deep-red visible spectral line in the Balmer series with a wavelength of 656.28 nm, it occurs when a hydrogen electron transits from its 3rd to 2nd lowest energy level. This transition produces H-alpha photon & the 1st line of Balmer series. [3]

$$\frac{1}{\lambda} = R \left[\frac{1}{n_f^2} - \frac{1}{n_i^2} \right] = R \left[\frac{1}{2^2} - \frac{1}{3^2} \right]$$

$$\frac{1}{\lambda} = 1.097 \times 10^7 \left[\frac{5}{36} \right]$$

$$\nu = \frac{c}{\lambda} = \frac{3 \times 10^8 \times 1.097 \times 10^7 \times 5}{36}$$

$$\nu = 4.57 \times 10^{14} \text{ Hz}$$

SECTION – E

31.

[5]

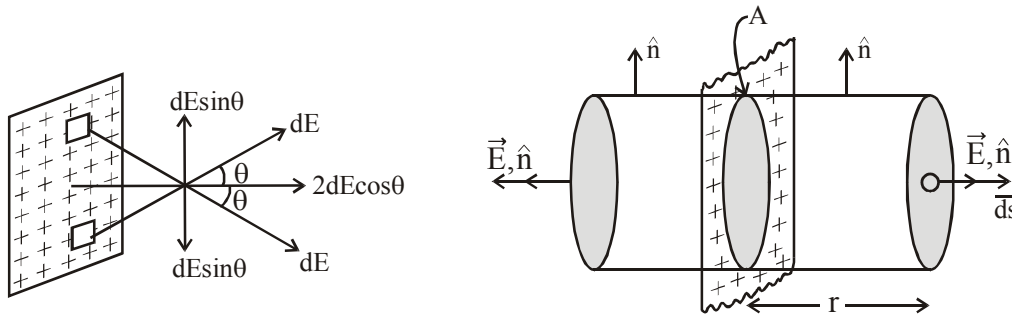

As shown in figure, considering a cylindrical gaussian surface of cross section A

(i) **Flux through curved surface :**

$$\phi = \vec{E} \cdot \vec{dS} = EdS \cos 90^\circ = 0$$

At the points on the curved surface, the field vector \vec{E} and area vector \vec{dS} make an angle 90° with each other. Therefore, curved surface does not contribute to the flux.

Flux through end caps :

$$\phi = \oint \vec{E} \cdot \vec{dS} = \oint EdS \cos 0^\circ = EA$$

Hence, the total flux through the closed surface is :

$\phi = \text{Flux through both end caps} + \text{flux through curved surface}$

$$\text{or } \phi = EA + EA + 0 = 2EA \quad (1)$$

Now according to Gauss' law for electrostatics

$$\phi = q/\epsilon_0 \quad (2)$$

Comparing equations (1) and (2), we get

$$\begin{aligned} 2EA &= q/\epsilon_0 \\ E &= q/2\epsilon_0 A \quad (3) \end{aligned}$$

The area of sheet enclosed in the Gaussian cylinder is also A. Therefore, the charge contained in the cylinder, $q = \sigma A$ as σ (surface charge density) = q/A

Substituting this value of q in equation (3), we get

$$\begin{aligned} E &= \sigma A/2\epsilon_0 A \\ \text{or } E &= \sigma/2\epsilon_0 \end{aligned}$$

This is the relation for electric field due to an infinite plane sheet of charge. The field is uniform and does not depend on the distance from the plane sheet of charge. Direction of field for positive charge density will be outwards from sheet and the same will be inward for negative charge density.

(ii) Let $C_1 = x$ and $C_2 = 2x$
equivalent capacitance in series combination

$$C_s = \frac{C_1 C_2}{C_1 + C_2} = \frac{x \times 2x}{x + 2x} = \frac{2x}{3} \quad \therefore C_s = \frac{2x}{3}$$

equivalent capacitance in parallel combination

$$C_p = C_1 + C_2 = x + 2x = 3x$$

Now given that energy stored in series combination = Energy stored in parallel combination

$$\frac{1}{2} C_s V_1^2 = \frac{1}{2} C_p V_2^2$$

$$\frac{1}{2} \times \left(\frac{2x}{3}\right) V_1^2 = \frac{1}{2} \times 3x \times V_2^2$$

$$\Rightarrow \boxed{\frac{V_1}{V_2} = \frac{3}{\sqrt{2}}}$$

OR

(a) Let consider a dipole system,

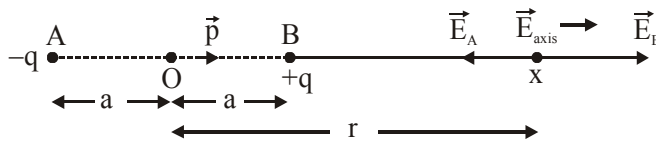

Here, $AO = OB = a$
 $OX = r$
 $BX = r - a$
 $AX = r + a$

Elec. field (\vec{E}_B), due to charge at point 'B' is towards \vec{p}

Elec. field (\vec{E}_A), due to charge at point 'A' is opposite to \vec{p}

Now, according to the superposition principle,

$$\vec{E}_{\text{axial}} = \vec{E}_A + \vec{E}_B$$

$$E_{\text{axial}} = \frac{-Kq}{(r+a)^2} + \frac{Kq}{(r-a)^2}$$

$$= Kq \left[\frac{1}{(r-a)^2} - \frac{1}{(r+a)^2} \right]$$

$$= Kq \left[\frac{(r+a+r-a)(r+a-r+a)}{(r-a)^2 (r+a)^2} \right]$$

$$= \frac{Kq(2r)(2a)}{(r^2 - a^2)^2}$$

$$\vec{E}_{\text{axial}} = \frac{2rk(2a)(q)}{(r^2 - a^2)^2} \hat{r} \quad \boxed{\because |\vec{P}| = 2a \times q}$$

$$= \frac{2K P \vec{r}}{r^4} \quad \boxed{\text{if } 2a \ll r}$$

$$\text{then } \vec{E}_{\text{axial}} = \frac{2K\vec{P}}{r^3} \hat{r}$$

Direction lies in the direction of electric dipole moment, p

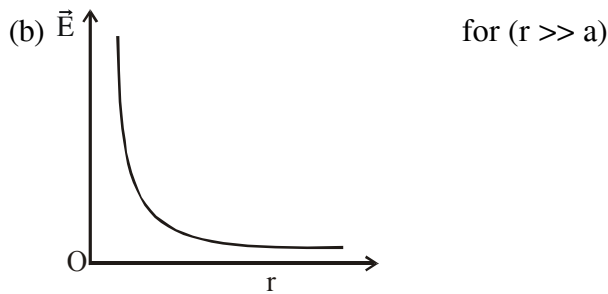

(c)

(i) Stable equilibrium -

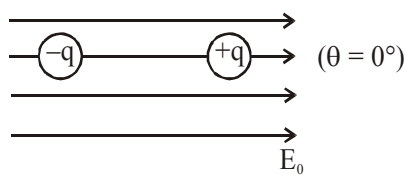

$$\begin{aligned} \text{Torque}(\tau) &= PE \sin\theta \\ &= PE \times \sin 0^\circ \\ &= 0 \quad (\because \sin 0^\circ = 0) \end{aligned}$$

(ii) Unstable equilibrium

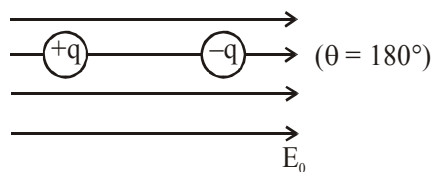

$$\begin{aligned} \text{Torque}(\tau) &= PE \sin\theta \\ &= PE \sin 180^\circ \\ &= PE \times 0 = 0 \quad (\because \sin 180^\circ = 0) \end{aligned}$$

32. (i) Source frequency, when current is maximum is given by

[5]

$$f = \frac{1}{2\pi\sqrt{LC}} = \frac{1}{2\pi\sqrt{8 \times 2 \times 10^{-6}}} \quad \{L = 8\text{H and } C = 2\mu\text{F}\}$$

$$f = \frac{1}{2\pi \times 4 \times 10^{-3}}$$

$$f = 39.80 \text{ Hz}$$

The frequency at which current maximum, is called resonant frequency.

(ii) given $E_0 = 200\text{V}$, $R = 100\Omega$

$$I_{\max} = \frac{E_0}{R} = \frac{200}{100} = 2\text{A}$$

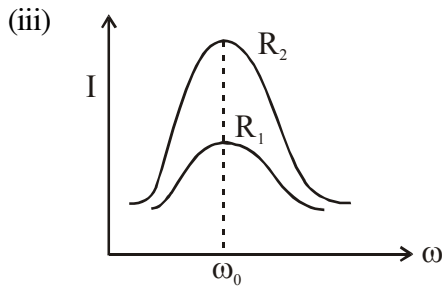

OR

Suppose OA, OB, OC represents the magnitude of phasor V_R , V_L and V_C respectively. In case of $V_L > V_C$, the resultant of (V_R) and ($V_L - V_C$), represented by OE. Thus from ΔOAE

$$OE = \sqrt{OA^2 + AE^2}$$

$$V = \sqrt{V_R^2 + (V_L - V_C)^2}$$

Substituting the value of V_R , V_L and V_C we have

$$V = \sqrt{(IR)^2 + (IX_L - IX_C)^2}$$

or
$$I = \frac{V}{\sqrt{(R)^2 + (X_L - X_C)^2}}$$

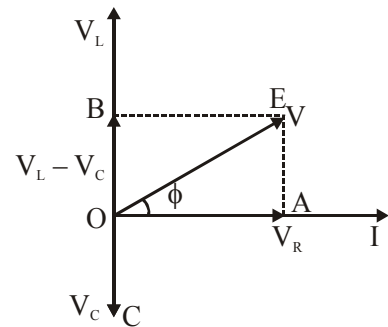

The effective opposition offered by L, C, R to a.c. supply is called impedance of LCR circuit and represented by Z.

$$I = \frac{V}{Z}$$

$$Z = \sqrt{R^2 + \left(\omega L - \frac{1}{\omega C}\right)^2}$$

Also from ΔOAE

$$\tan \phi = \frac{AE}{OA} = \frac{V_L - V_C}{V_R}$$

or
$$\tan \phi = (X_L - X_C)/R$$

or
$$\phi = \tan^{-1} \frac{(X_L - X_C)}{R}$$

Power dissipation in LCR circuit :

The instantaneous power supplied by the source is

$$P = VI$$

$$P = (V_m \sin \omega t) \times i_m \sin(\omega t + \phi) = \frac{V_m i_m}{2} [\cos \phi - \cos(2\omega t + \phi)]$$

$$[2 \sin A \sin B = \cos(A-B) - \cos(A+B)]$$

For average power the second term becomes zero in the complete cycle.

So
$$P_{av} = \frac{V_m i_m}{2} \cos \phi$$



$$P_{av} = \frac{V_m}{\sqrt{2}} \frac{i_m}{\sqrt{2}} \cos\phi = V_{rms} i_{rms} \cos\phi$$

$$P_{av} = V_{rms} i_{rms} \cos\phi$$

At resonance condition $\cos\phi = 1$ (because $\phi = 0$), so R becomes effective impedance of a circuit. So power dissipated is maximum at resonance condition.

33. The phenomenon of bending of light around the sharp corners and spreading into the regions of the geometrical shadow is called diffraction. [5]

Diffraction from a slit. A narrow slit of width a is placed at a distance D from the screen. When the slit is illuminated with a monochromatic light of wavelength λ , then alternate bright and dark bands of light are formed on both the sides of the central maximum.

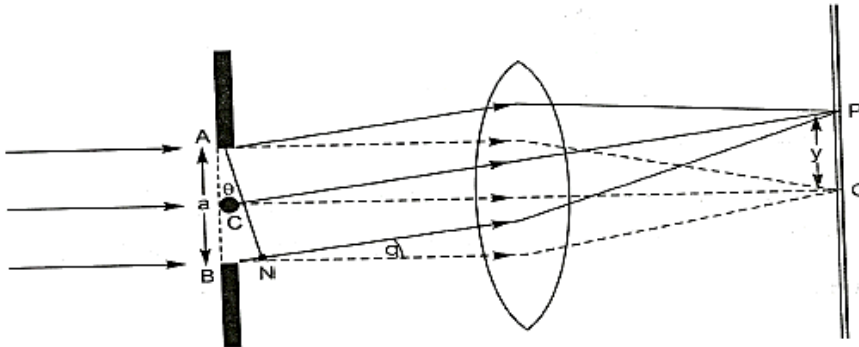

Path difference between the secondary waves reaches at point P

$$BN = AB \sin\theta = a \sin\theta$$

If $BN = \lambda$ and $\theta = \theta_1$

$$\lambda = a \sin\theta_1$$

$\sin\theta_1 = \frac{\lambda}{a}$, θ_1 is the angle up to which the central maxima can extend.

Such angular position on the screen will represent the first secondary minimum. We assume the slit to be divided into two equal halves, the wavelets from the corresponding points of the two halves of the slit will have a path difference of $\frac{\lambda}{2}$, i.e., they reach point P in opposite phase. Hence for second secondary minimum,

$$2\lambda = a \sin\theta_2$$

$$\sin\theta_2 = \frac{2\lambda}{a} \text{ and } \sin\theta_n = \frac{n\lambda}{a} \text{ for } n^{\text{th}} \text{ secondary minima}$$

If y_n is the distance of n^{th} sec. minimum from the screen, then

$$\tan\theta_n = \frac{OP}{CO} = \frac{y_n}{D}$$

For small n ,

$$\sin\theta_n = \tan\theta_n$$

$$\frac{y_n}{D} = \frac{n\lambda}{a}$$

$$y_n = \frac{n\lambda D}{a}$$

therefore $\beta = y_n - y_{n-1} = \frac{\lambda D}{a}$

For first sec. maxima



$\sin\theta_1' = \frac{3\lambda}{2a}$ { Since the wavelets from each half will reach point P such that out of three equal parts two will cancel out leaving one parts of wavelet to produce the bright fringes.

Similarly, $\sin\theta_2' = \frac{5\lambda}{2a}$

$\sin\theta_n' = \frac{(2n+1)\lambda}{2a}$ force n^{th} sec. maxima

Therefore $\beta' = y'_n - y'_{n-1} = \frac{\lambda D}{a}$ Both sec. maxima and minima are of same width.

Width of a central maximum : $\beta_0 = \frac{2D\lambda}{a}$

OR

(a) Wavefront : It is defined as the locus of all the points vibrating with zero or constant phase difference.

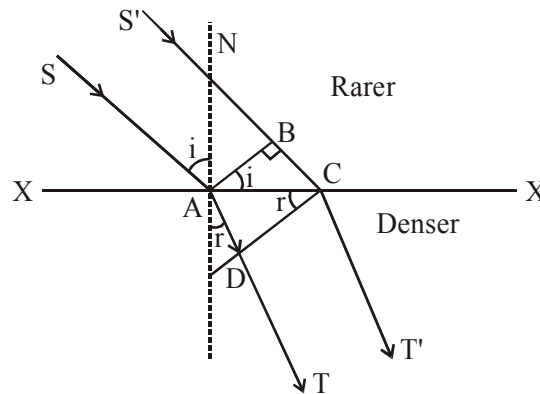

Proof of law of refraction (Snell's Law)

Consider a plane wavefront (AB) incident on the surface XY, separating two media. Let the secondary wavelets from point (B) reach upto point (C) in time (t). So draw an arc of length (v_2t) from point A to locate the position of refracted wave front. Now we draw a tangent (CD) on this arc where CD represents refracted wave front.

Clearly incident ray, refracted ray & the normal are respectively \perp to incident wave front, refracted wavefront and surface XY.

Also, $\sin i = \frac{BC}{AC} = \frac{v_1 t}{AC}$ (i)

& $\sin r = \frac{AD}{AC} = \frac{v_2 t}{AC}$ (ii)

From (1) & (2),

$$\frac{v_1}{v_2} = \frac{\sin i}{\sin r}$$

or $\frac{\mu_2}{\mu_1} = \frac{\sin i}{\sin r}$ Snell's Law